

Challenges and Solutions in Planning Information Systems for Networked Value Constellations

Novica Zarvić*

Maya Daneva†

University of Twente, Department of Computer Science, Information Systems Group
P.O. Box 217, 7500 AE Enschede, The Netherlands
{n.zarvic, m.daneva}@ewi.utwente.nl

Abstract: Nowadays businesses often decide to form networked value constellations in order to satisfy complex customer needs. To fulfill the value-based requirements of an e-Business idea and to realize the coordination of such a multi-actor network an adequate underlying information systems architecture has to be conceptualized. This paper discusses the applicability of classical information system planning approaches, such as Information Engineering to cross-organizational settings expressed through value-based requirements. On the basis of this analysis several requirements for the enhancement and adaptation of Information Engineering-like methodologies for e-Business ideas are defined for the purpose of enabling alignment between a value-based business context and the information systems architecture in a networked environment. The paper proposes a way to derive data-orientation from value-orientation, i.e. an enterprise model from a value model. This in turn enables afterwards the straightforward use of traditional data-oriented techniques for value-based business models.

1 Introduction

The biggest challenge in information systems (IS) planning and design is the alignment of IS to the business context [WBFG03]. The adequate allocation of IS to business needs must be considered as one of the fundamental factors in IS development, because only a well coordinated IS landscape will lead to the fulfillment of the given business goals. Coordination of IS plans and business plans is not a new problem and the difficulty of achieving it was addressed in most organizations by using structured IS planning methodologies [LM89]. In businesses of any significant size, however this problem is not solved completely. With the advent of the internet many profit-and-loss responsible business units, or often independent companies, form so-called *networked value constellations*, which makes the situation even more difficult [WGvE05], because most businesses cannot be viewed anymore as single enterprises. Such networked cooperations are enabled

*Supported by the Netherlands Organisation for Scientific Research (NWO), project 638.003.407, Value-based Business-IT Alignment (VITAL)

†Supported by the Netherlands Organisation for Scientific Research (NWO), project 632.000.000.05N01, Collaborative Alignment of cCross-organizational ERP Systems (CARES)

by means of ICT (information and communication technology) and it is the goal of this paper to explore how to match ICT-services with the requirements of a value-based business model. Typically in networked value constellations almost all services are e-services, services produced by ICT-systems. Examples are on-line music delivery, e-mail services, and information services.

Tagg and Freyberg argue that “no methodology, however well-championed, has ever kept a monopoly on the truth for very long. Both the Technology and Business Application ends of IS have been so fast moving that the ‘design equation’ is always changing” [TF97]. This makes it clear that the IS ‘design equation’ has an evolutionary character, i.e. existing methodologies are permanently (depending on predefined or evolving requirements) adjusted and enhanced [Bin96].

This paper is structured as follows. Section 2 gives an introduction to ISP methodologies, especially to Information Engineering. The notion of networked value constellations is described in detail and the adequacy of Information Engineering for such constellations is discussed. Section 3 defines the additional steps needed to enhance existing methodologies, before in Sec. 4 the main artifacts of an enterprise model are derived from a value model. Finally, Sec. 5 concludes the paper.

2 Information Systems Planning Methodologies and Networked Value Constellations

Strategic planning for information systems is the discipline to position an organization to proactively take advantage of its future by anticipating opportunities and challenges in a dynamic and complex environment and by providing the roadmaps that master change. In today’s interconnected business world, strategic planning is the vehicle organizations use to attain business/IT alignment. Recent empirical studies [CST06, BH06, RB00] indicate that planning directly impacts the development of shared business-IT knowledge, and, consequently, alignment between business and IT strategy. For network businesses, the purpose of strategic planning processes is to bring business and IS senior managers from partner companies together repeatedly in identifying, assessing, and realizing technology-related opportunities and managing challenges. Although this is well recognized as a key to the successful implementation of inter-organizational information systems, very little empirical and theoretical research has been done on strategic planning processes for inter-organizational systems [FGP03]. As a result, practitioners are left with little coherent planning advice for approaching network constellations. In the next sections, we seek to address this deficit. We provide a summary on the family of Information Engineering-like methodologies, analyze why existing approaches offer little support to systems planners in business networks, and define what should be included in new, enhanced approaches to inter-organizational systems planning.

2.1 Summary of Information Engineering

Many different IS planning methodologies are discussed in the literature [PS95, PR01] as well as the need for designing new methodologies or adapting existing approaches to specific environments and requirements [IA05, WG98]. The ability to involve top management in the systems planning activity is an important strength [Mar82] and has the aim to ensure that the information systems direction is linked to the business direction. In this paper we focus on an IS planning methodology called *Information Engineering* (IE). IE was initially created by Clive Finkelstein [Fin89] who is known as the “father of information engineering”. However, other associate the term IE with James Martin who popularized this methodology during the 1980’s through various publications [Mar89] and through his consulting company “James Martin Associates”. It became then a *de facto* standard in IS planning and this explains that also major computer companies like Texas Instruments [Bin96] acted successfully in this field. James Martin defined Information Engineering as “The application of an interlocking set of formal techniques for the planning, analysis, design, and construction of information systems on an enterprise-wide basis or across a major sector of the enterprise [Mar89].”

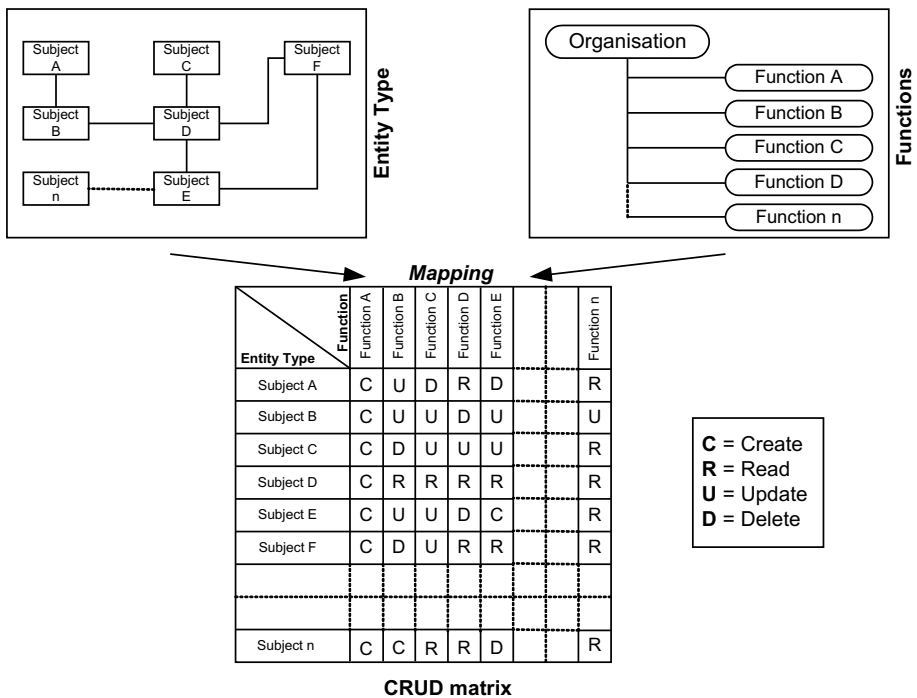

Figure 1: Mapping entity types against functions by means of a CRUD matrix

This definition makes the different steps of IE clear, which are often represented with

the help of the information systems pyramid. In short, IE is concerned with the creation of *enterprise models*, *data models* and *process models* in a top-down manner. The last step usually requires that functions/processes need to be divided and allocated to systems that support them. In case of small companies with few functions this can be realized by looking which IS are supporting the identified functions. But usually there are hundreds of functions and in such case the systems are determined by means of CRUD analysis, which takes subject areas and business functions into account. Subject areas are entities about which an enterprise wants to save information (e.g. products, customers). A business function is a group of activities in an enterprise (e.g. purchasing, receiving). Business functions are sometimes grouped into higher-level functional areas [Mar89]. Tagg and Freyberg call *clustering* the “engine room” of most IS planning methods which aids the identification of smaller units which are relatively self-contained. In order to do so the entities need to be mapped against functions like shown in Fig. 1. The letters C, R, U or D in the cells of the CRUD matrix show whether a function *creates*, *reads*, *updates* or *deletes* instances of an entity. Clustering itself is a process of reordering the rows and columns of the CRUD matrix such that the most C, D and U cells are grouped into rectangular blocks like shown exemplary in Fig. 2. These rectangular blocks represent natural systems and point out the relationship between data subjects and functions. Note that IS planning usually ends up with the identification of such systems [TF97].

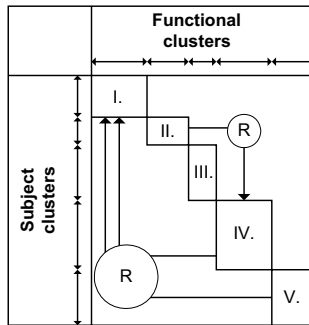

Figure 2: Clustered CRUD matrix (cf. [TF97])

Although IE as a methodological approach is overaged today [Hay03], many techniques from the traditional IE methodology are still used in practice. The term itself disappeared in the middle of the 1990's from the scene, but was revived through various “new” Information Engineering study courses at different academic institutions (e.g. Hogeschool van Amsterdam in the Netherlands ¹, National Taiwan University ², Australian National University ³, University of Osnabrück in Germany ⁴) throughout the world. Note that the curricula of this study courses do not have necessarily much in common with the primarily IE like presented by James Martin.

¹ See <http://www.iie.hva.nl/>

² See <http://www.csie.ntu.edu.tw/>

³ See <http://rsise.anu.edu.au/>

⁴ See <http://www.inf-eng.org/>

2.2 The Context of Networked Value Constellations

Networked value constellations are networked businesses that focus especially on how economic value is created and exchanged within a network of actors. For the purpose of this paper we borrow Santana Tapia's definition of a networked business: it is "a web of profit-and-loss oriented business units, or of independent companies, that work together for a common purpose on a specific period of time" [Tap06]. Such a network is enabled by means of ICT [WGvE05]. An example of a business network is WalMart Stores Inc. who collaborates with a large number of non-U.S. companies and gives them direct access to the American market. In the context of a networked business, system planning begins as a learning process where partner companies are studying inter-organizational support technologies and how they can benefit from these technologies in specific circumstances [FGP03]. This helps conceptualize a value exchange model that serves as a business argument used later to devise cross-organizational coordination processes and systems to support them. The discipline of requirements engineering for such systems postulates that inter-organizational IS analysis and design includes three distinct viewpoints on the system under consideration [GA01, GA03], a *value viewpoint*, a *process viewpoint*, and a *IS viewpoint*. The value viewpoint is the top-level viewpoint and focuses on value creation, distribution and consumption. It is usually the first step in designing and analyzing a networked value constellation. Gordijn proposes the e^3 - *value* methodology as a representation technique for modelling the business from a value viewpoint. The other viewpoints to be considered are the process viewpoint and the IS viewpoint. All the viewpoints represent different *Universes of Discourse*, but are nevertheless describing the same sociotechnical system, and therefore mutually adapt to each other. This means that a change in one viewpoint will most probably lead to changes in the other two viewpoints. The main relationship between these viewpoints is a *put into operation relation*, that is, the system presented through the IS viewpoint puts into operation the processes described in the process viewpoint which - in turn, put into operation the value-based business model. Following these authors [GA01, GA03] our emphasis in this paper is on the *value viewpoint*.

Figure 3 shows an example networked value constellation by Derzsi and Gordijn [DG06, p. 222] using the e^3 - *value* notation. The example describes the so-called "travelling salesman" - case. In this case a salesman travels internationally and wants to have wireless Internet access in the hotels, where he is residing. As far as the e^3 - *value* notation is suited for describing the flow of *goods* and/or *services*, the wireless internet connection represents in this case a service and the room which the salesman rents represents a good. Of course the hotel does not provide the salesman these value objects for free, but demands something of value in return (fee). In this case the hotel offers the wireless connectivity by itself and uses an internet service provider (ISP) to have internet connectivity.

In short, in e^3 - *value* a business *actor* is a profit-and-loss responsible business unit, like the hotel in our example case. It is represented by means of a rectangle. A *market segment* is a group of actors that share the same needs and is represented as three stacked actors such as the traveller. Actors and market segments exchange *value objects* (e.g. money for IP access). This is realized through *value ports*, which are located at the *value interfaces*. A value interface consists of *in* and *out* ports that belong to the same actor or market

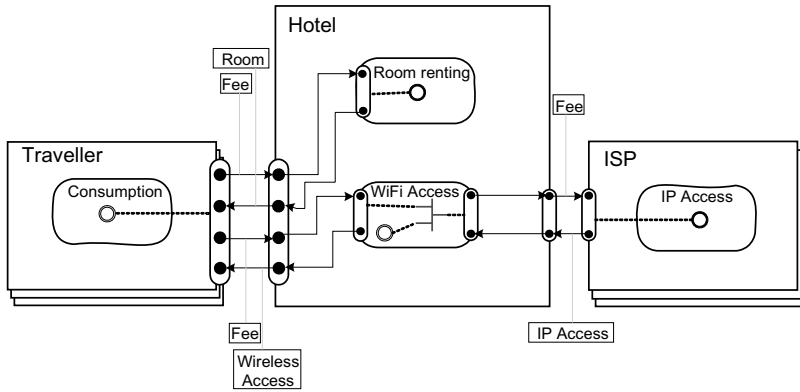

Legend				
	Market segment	Actor	Value interface with two ports	Value activity
			e.g.	
Start stimulus	End point	Value exchange	Value object	AND and OR forks

Figure 3: Example e^3 - value model “Travelling Salesman”

segment. A *value exchange* is used to connect two value ports with each other and is shown as line between the value ports. A *value activity* is graphically represented as a rounded box drawn inside an actor or market segment, like e.g. WiFi access in Hotel. It represents assignment of value activities to actors. A scenario path begins with a *start stimulus*, which in turn usually represent some kind of need. In our example, the traveller has the need to get a room and to have wireless internet-access. The hotel’s business need (or strategic goal) is to offer such wireless connectivity and thus it has the need towards a certain type of IP access. Further, *AND* and *OR* elements can be used to specify the scenario execution.

2.3 On the Adequacy of Traditional Information Engineering-like Methods for Networked Value Constellations

Methodologies are organized as documented sets of steps and procedures for accomplishing a desired task. Many methodologies (such as IE) include diagramming notations (e.g. entity relationship diagrams) for documenting the results of a certain step. They all start with developing an enterprise model first and then deriving process and data models from the enterprise model. In the literature, the only exception from this planning process is suggested by Gordijn [GA01, GA03], who recommends planners to first focus on the value viewpoint and the conceptualization of a value-base business model and, then, develop the models reflecting the other viewpoints. However, a danger of such multi-perspective

approaches is that a specific viewpoint only implies a partial specification of the system from a particular stakeholder’s view. Such a separation of concerns leads to potential inconsistencies between specifications from different perspectives, which may result in a technically non-implementable system. *Consistency checking methods* are currently the only way to ensure successful implementation [ZW05]. Our literature review indicates that, to the best of our knowledge, there is no IS planning methodology that takes value-based requirements as a starting point for determining the IS landscape of a networked value constellation into account. To improve this situation, we propose an enhancement of the existing IE methodology that will meet the following needs of cross-organizational systems planners:

- focusing on multiple enterprises that make up a value web.
- taking requirements from the value viewpoint into account.
- deriving enterprise models from value models.
- taking existing (legacy) systems into account.
- quantitatively analyzing IS architecture options.

Our envisioned IS planning methodology for networked value constellations will enhance existing systems planning practices in four aspects which are summarized in Tab. 1.

Aspect	Traditional IE	IS Planning for Value Networks
business model	enterprise model	value model
organizational structure	single enterprise	networked value constellation
process model	internal business processes	inter-organizational coordination processes
scope	computerize an enterprise from the “scratch”	computerize just the e-business idea (by taking legacy systems into account)

Table 1: Main differences between traditional IE and proposed IS planning methodology for networked value constellations

First, the starting point in cross-organizational systems planning at the strategic level will be the network business model. Its main purpose is to provide a big-picture view of the business (units). This new starting point is an enhancement to traditional IE which puts the enterprise model first. Second, our focus on the value model makes explicit the economic value aspect in network constellations, whereas an enterprise model is focused rather on the company’s organizational structure. Third, because traditional approaches focus on single enterprises, they address the needs to model internal business processes only. In contrast to this, our envisioned methodology will keep its focus on multiple enterprises and will allow planners to conceptualize inter-organizational coordination processes that

will operationalize the overlaying value model. Fourth, the new methodology reflects the most recent shifts in the scope of system planning. Traditional IE assumes that planners start from the scratch and completely computerize an enterprise, whereas the adapted methodology would computerize just the e-business idea. This means that, with the new methodology, (i) a systems planning exercise will be focused on the IS landscape that covers only those parts of the business units which are necessarily involved in implementing the e-business idea, and (ii) the planner will not start from a green field, but will consider and possibly re-use legacy systems.

Our analysis makes it clear that the traditional IE approach is not enough to confront the needs of planners in networked value constellations settings. This motivated our efforts to enhance current cross-organizational planning practices. We, however, do not envision to arrive at a completely new methodology, but rather to enhance and adapt existing practices to this new situation. In what follows, we present our initial proposal for an enhanced IE-like methodology and, then, we narrow down the discussion to address one specific question in our proposal, namely, the concern of how to derive a networked enterprise model from a value model.

3 An enhanced Information Engineering-like methodology for Networked Value Constellations

Figure 4 shows our proposed IS Planning methodology. Three major enhancements to traditional IE-like methodologies ([B] in Fig. 4) can be identified:

- [A] deriving (networked) enterprise model from a value model,
- [C] the consideration of legacy systems, and
- [D] economic-driven IS architecture support.

From Value Model to Enterprise Model. We attempt to derive an enterprise model from a value model ([A] in Fig. 4), i.e. we derive data-orientation from value-orientation. This is an important and challenging enhancement in the new methodology, because it enables the straightforward application of the traditional IE-like techniques afterwards ([B] in Fig. 4).

Considering legacy systems. Traditional systems planning approaches have the aim to computerize an uncomputerized enterprise, but these approaches usually end with the identification of natural systems after performing CRUD analysis. Networked value constellations are usually already computerized, i.e. participating partners have an IS landscape. The challenge here ([C] in Fig. 4) is to understand how the proposed natural systems relate to legacy systems. As far as businesses want to reuse their legacy systems, a “gap analysis” has to be performed.

Quantitative decision support. As far as a networked value constellation represents a multi-actor network of independent (profit and loss oriented) business actors, systems realizing coordination among multiple actors might be identified in the previous steps. In order to do so, it must be determined which actor should own and purchase such a system. Such architectural decisions must be made on a rational basis and must be feasible from an economic point of view ([D] in Fig. 4) [Zar06].

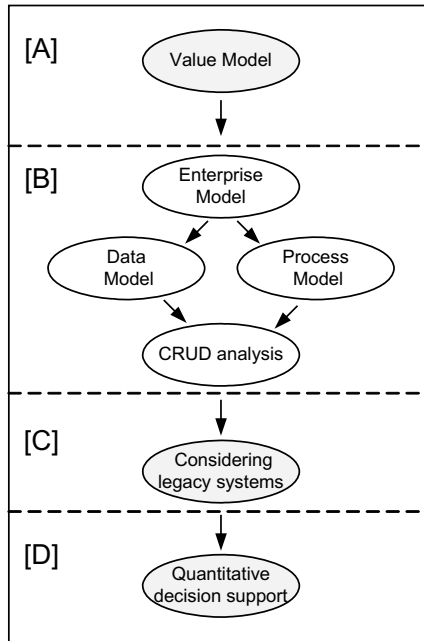

Figure 4: Proposed IS Planning methodology for Networked Value Constellations

In this paper, we concentrate on the first enhancement [A] and show in the next section how to derive an enterprise model from a value model.

4 From Value Model to (Networked) Enterprise Model

Martin describes that the first step in top-down planning is “to create a chart or model of the enterprise” [Mar82, p. 21]. In our approach this is the second step and in order to arrive there, we need to map *value requirements* to such *data requirements*.

Enterprise Models may vary in the degree of detail, depending on how detailed such models are created or on the dimension of the enterprise. This section shows how we get from value models to enterprise charts/models (in this case networked enterprise models). This is achieved by taking (i) e^3 - value model as well as the (ii) the textual e-business case de-

scription itself into account, because the latter one might contain information not included in the conceptual value model. In the following we give some guidelines, which are also summarized in Tab. 2.

e^3 - value model	Networked enterprise chart
name of value model	highest level in the enterprise chart
value actor and market segments	second level representing the independent business division
value activities	operational activities (functional areas)
value objects and value ports	additional information about operational activities
textual e-business description	additional information about operational activities

Table 2: Deriving a networked enterprise chart from e^3 - value modeling artifacts

The highest level of the enterprise chart is determined by the name of the value model itself, in our case the “travelling salesman”. This ensures that we are talking about the same e-business constellation. The second level is a straightforward mapping of the different value actors and market segments. These represent the profit-and-loss oriented business units. The value activities these business units perform represent then the next level in the enterprise chart, like e.g. WiFi Access. At this point the difference between value models and process models come into play. The main goal of a value model is to answer *who* is offering *what* to *whom* and expects *what* in return, whereas the process viewpoint is concerned with *how* these value activities are realized [GA03]. Therefore a “value activity forms the linking pin to operational activities” [DG06] and functional areas respectively. Functions like authentication or traffic encryption realize the value activity WiFi Access properly. Therefore functional decomposition of the identified functional area gains in importance. Additionally the value objects themselves as well as the value ports give us indications, e.g. fee/money transfer is realized through some accounting-like function. Last, we can possibly identify from the textual description of the e-business case information not contained in the value model, such as is the case described in [ZW05] where the model shows that fee has to be paid for a certain value object but not how. This can be extracted from the textual description (e.g. cash or bank transfer).

For the example from Fig. 3 the networked enterprise chart is shown in Fig. 5, which in turn enables straightforward use of traditional data-oriented IS planning techniques. Note that the above figure shows only the functions of the e-business idea. The hotel might have additional functions and business areas not listed here, like e.g. food and beverage, personnel, telephone switchboard. An ISP on the other side could next to IP Access also offer services such as registration of domains or act as a content provider. This is the reason why we are talking about a “computerized e-business idea” and not in the classical sense of a “computerized enterprise”.

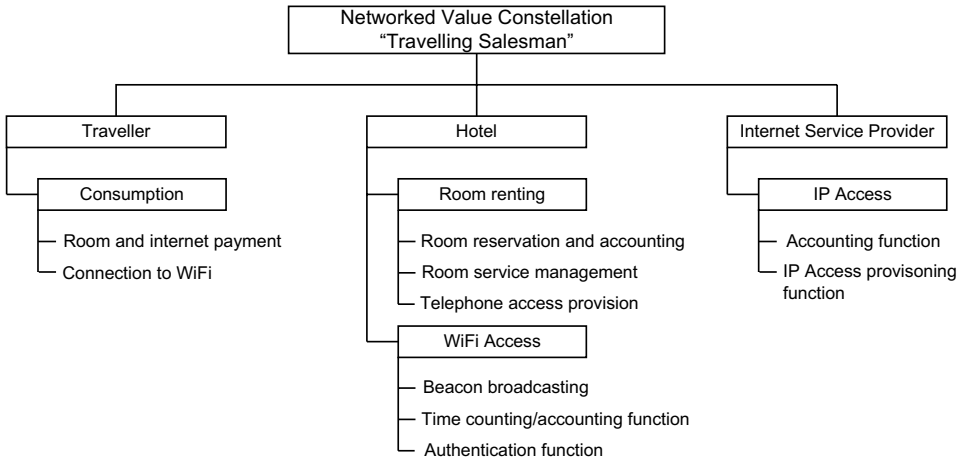

Figure 5: Networked enterprise chart derived from value model of “Travelling Salesman” case

5 Summary

Discussion. In this paper we presented our approach of how to migrate from value-based requirements to data-orientation in order to help systems planners the use of traditional data-oriented systems planning techniques for networked value constellations. It should be noted that the IS landscape, as the outcome, is just representing a global view. In real life two kinds of Networked Value Constellations are conceivable. First, one business actor is so powerful and decides on the architecture so that if smaller actors want to participate in the e-business idea, they need to accept the rules of this business actor [FGP03]. An example of such case is the automotive industry, where small suppliers need to adapt to the given interfaces of big car manufacturers. Second, each actor has the same power in the network, so that the global view, like shown in this paper, can be the driver for the IS landscape.

Future Work. Our current approach rests on experiences published in the literature that indicated why existing methods come short when planning cross-organizational systems. A limitation of this approach is that we did not determine it based on context attributes in a real-life case study. However, informal conversations with business partners from our project indicate that it makes sense to try it out in their planning settings. We, therefore, plan in the future a series of case studies of different size in the Netherlands in which we hope to gain more knowledge on the organizational context characteristics that favour the application of our methodology and the ones that make it weak. This, of course, includes further research and refinement of the presented steps. We also plan to refine and extend existing recommendations for good systems planning practices from earlier published experiences [FGP03].

References

- [BH06] S. Berman and J. Haggan. How technology-driven business strategy can spur innovation and growth. *Journal of Strategy and Leadership*, 34(2):28–34, 2006.
- [Bin96] C. Binkert. Eine systematische Vorgehensweise für Anwendungsprojekte. In W. Brenner, C. Binkert, and M. Lehmann-Kahler, editors, *Information Engineering in der Praxis*. Campus Verlag, Frankfurt, 1996. (In German).
- [CST06] Y. Chan, R. Sabhervawal, and J. Thatcher. Antecedents and Outcomes of Strategic IS Alignment: an Imperial Investigation. *IEEE Transactions on Engineering Management*, 53(1):27–47, 2006.
- [DG06] Z. Derzi and J. Gordijn. A Framework for Business/IT Alignment in Networked Value Constellations. In *Proceedings of Workshops and Doctoral Consortium of the 18th International Conference on Advanced Information Systems Engineering (CAiSE'06)*, Luxembourg, 2006.
- [FGP03] P. Finnegan, R. Galliers, and P. Powell. Systems Planning in Business-to-Business Electronic Commerce Environments. *Journal of Information Technology and Management*, 4(2-3):183–198, 2003.
- [Fin89] C. Finkelstein. *An Introduction to Information Engineering - From Strategic Planning to Information Systems*. Addison-Wesley, Sydney, 1989.
- [GA01] J. Gordijn and H. Akkermans. Designing and Evaluating E-Business Models. *IEEE Intelligent Systems*, 16(4):11–17, July/August 2001.
- [GA03] J. Gordijn and H. Akkermans. Value-based requirements engineering: exploring innovative e-commerce ideas. *Requirements Engineering*, 8(2):114–134, July 2003.
- [Hay03] D. Hay. *Requirements Analysis*. Pearson Education, New Jersey, 2003.
- [IA05] I. Ishak and R. Alias. Designing a Strategic Information Systems Planning Methodology for Malaysian Institutes of Higher Learning (ISP-IPTA). *Issues in Information Systems*, VI(1):325–331, 2005.
- [LM89] A. Lederer and A. Mendelow. Coordination of Information Systems Plans with Business Plans. *Journal of Management Information Systems*, 6(2):5–19, 1989.
- [Mar82] J. Martin. *Strategic Data-Planning Methodologies*. Prentice-Hall, New Jersey, 1982.
- [Mar89] J. Martin. *Information Engineering*. Prentice Hall, New Jersey, 1989. Three Volumes.
- [PR01] S. Pant and T. Ravichandran. A framework for information systems planning for e-business. *Logistics Information Management*, 14(1/2):85–98, 2001.
- [PS95] S. Pant and C. Su. Strategic Information Systems Planning: A Review, 1995.
- [RB00] B. Reich and I. Benbasat. Factors that Influence the Social Dimension of Alignment between Business and Information Technology Objectives. *MIS Quarterly*, 24(1):81–113, March 2000.
- [Tap06] R. Santana Tapia. What is a Networked Business? Technical report, University of Twente, 2006.
- [TF97] R. Tagg and C. Freyberg. *Designing Distributed And Cooperative Information Systems*. International Thomson Computer Press, 1997.

- [WBF03] R. Wieringa, H. Blanken, M. Fokkinga, and P. Grefen. Aligning Application Architecture to the Business Context. In *Conference on Advanced Information System Engineering (CAiSE 03)*, pages 209–225. Springer, 2003. LNCS 2681.
- [WG98] A. Wong and F. Gregory. The Inapplicability of Western Models to Information Technology Development in Chinese Companies - The Case of the Hong Kong Newspaper Industry. In *Proceedings of the Fifth IFIP WG 9.4 Working Conference: Implementation and Evaluation of Information Systems in Developing Countries*, Bangkok, February 1998.
- [WGvE05] R. Wieringa, J. Gordijn, and P. van Eck. Value-Based Business-IT Alignment in Networked Constellations of Enterprises. In *Proc. 1st International Workshop on Requirements Engineering for Business Needs and IT Alignment (REBNITA 2005)*, 2005.
- [Zar06] N. Zarvic. Value-Based Requirements Engineering and IS Architecture Design Support for Cross-Organizational Environments. In *Proceedings of the Doctoral Symposium of the 14th IEEE International Requirements Engineering Conference (accepted)*, 2006.
- [ZW05] Z. Zlatev and A. Wombacher. Consistency between e^3 - value Models and Activity Diagrams. In *On the Move to Meaningful Internet Systems 2005: CoopIS, DOA, and ODBASE: OTM Confederated International Conferences, CoopIS, DOA, and ODBASE 2005*, pages 520–538, Cyprus, November 2005.

